

APPLICATION NOTE

Compensating Stackers

Problem

Stacks of magazines (as delivered to newsagents) and books are created in compensating stackers. Magazines/books are fed into the compensating stacker where they are collated into a stack (a pre set number). The stack is then transferred by conveyor to either a strapping machine or automatic palletizer. Due to the slippery nature of the covers, the magazines/books slip as the stack travels along the conveyor, resulting in incorrect stack heights or poor stack presentation.

Solution

Static generating equipment is installed to 'pin' the stack together, thus ensuring that it stays in perfect shape for the next operation. This saves considerable manpower that is otherwise needed to re-stack the piles.

Fig.

Compensating stacker
fitted with charge bars

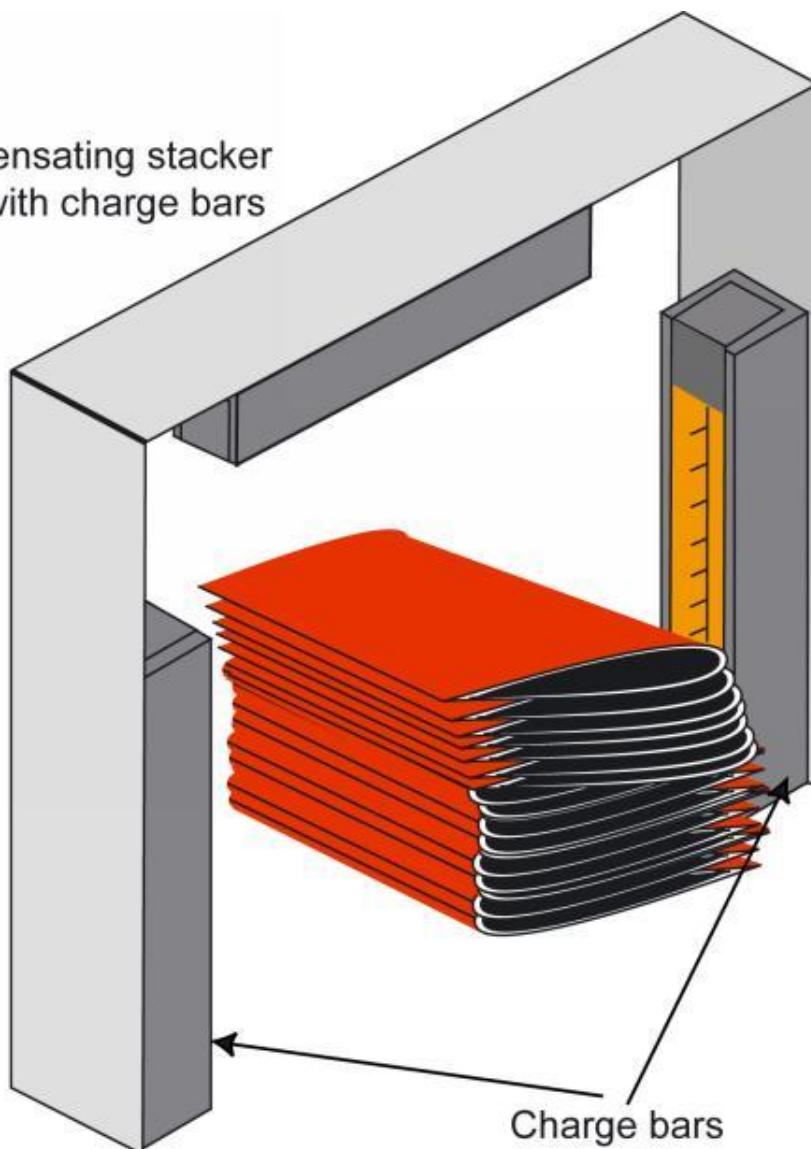

Meech International

2 Network Point
Range Road, Witney
OX29 0YD, UK

Tel: +44 (0) 1993 706700

Fax: +44 (0) 1993 776977

email: sales@meech.com